

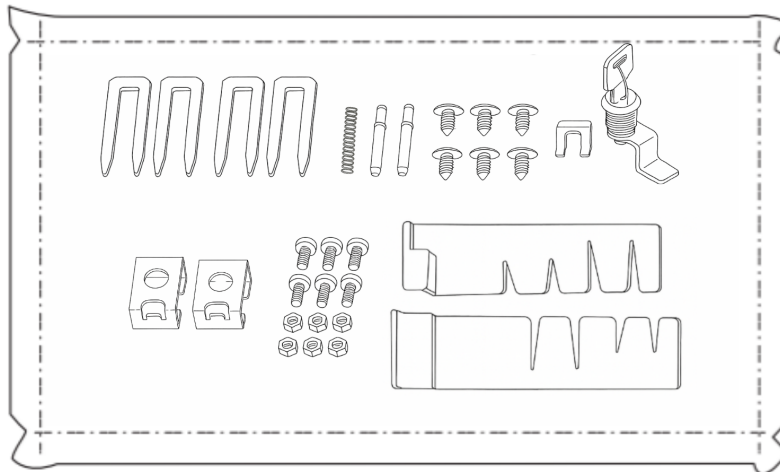

Requires the use of screwdriver
 Necesario uso de destornillador
 Utilisation nécessaire d'un tournevis
 Verwendung Schraubendrehers notwendig



Wearing protective gloves and the use of a rubber hammer is recommended
 Se recomienda usar martillo de goma y guantes
 Recommandé utiliser un marteau en caoutchouc et des gants
 Verwendung von Handschuhen und Gummihammer wird empfohlen



1

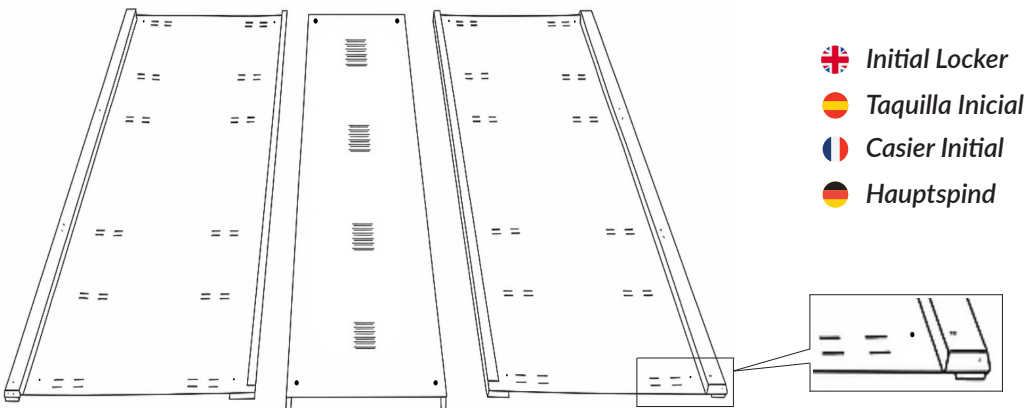

2

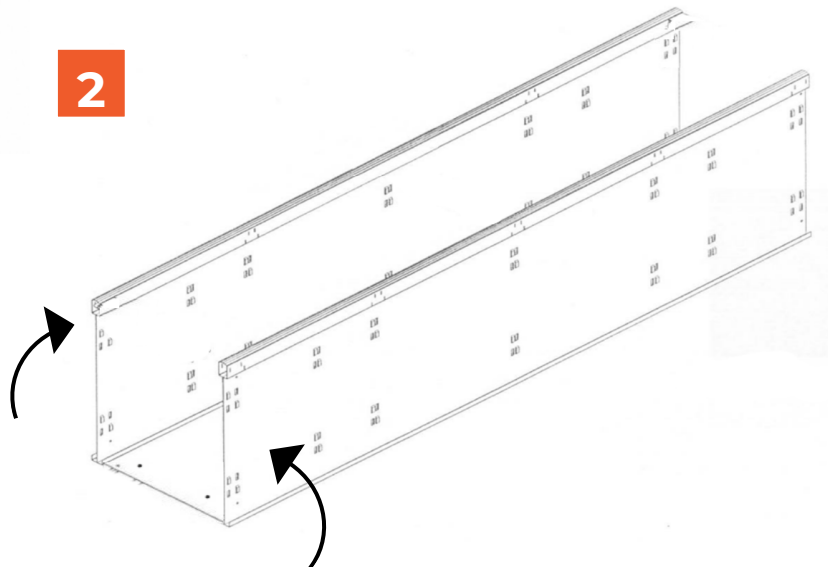

3

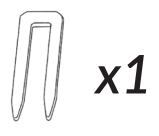

x1

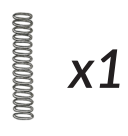

x1

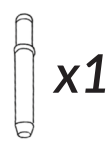

x1

3.1

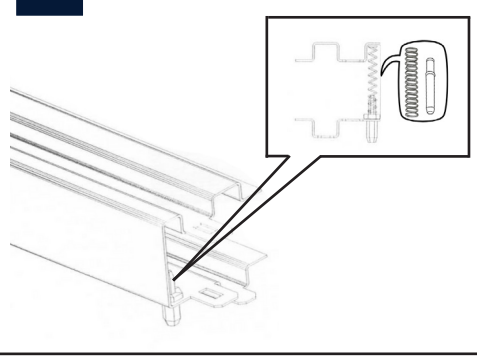

3.2

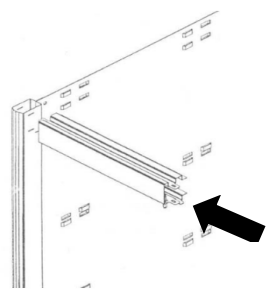

3.3

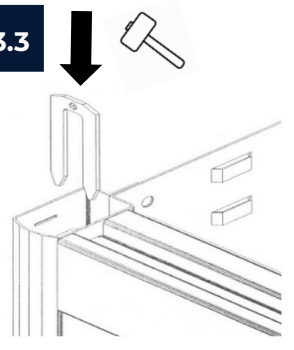

4



x1

4.1

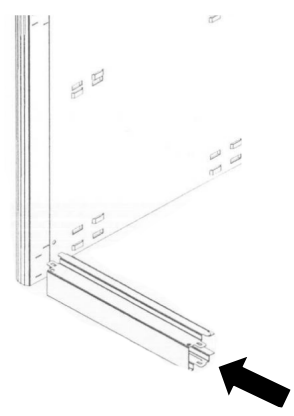

4.2

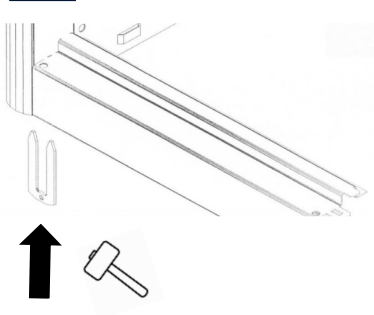

5

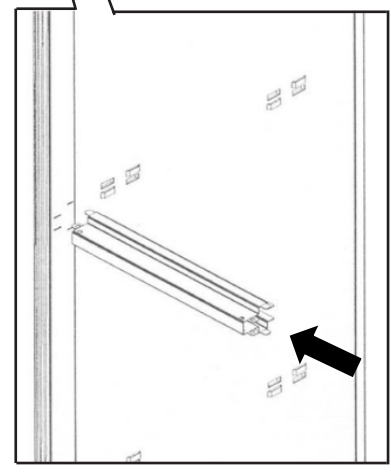



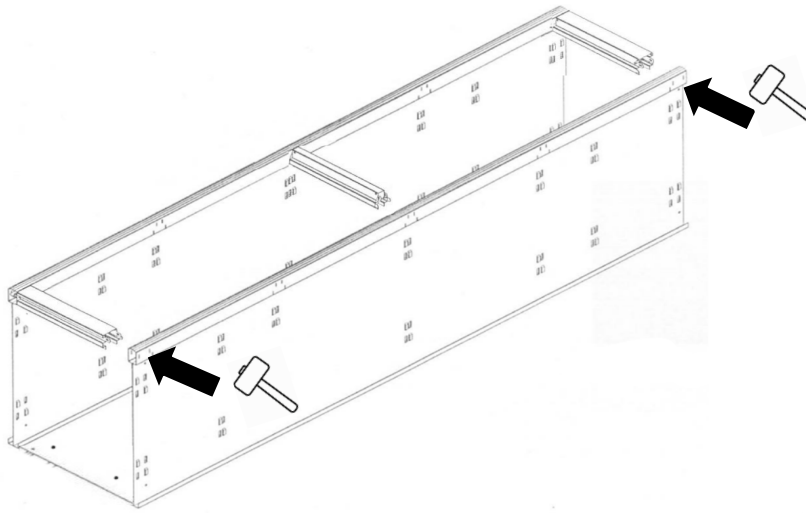

6

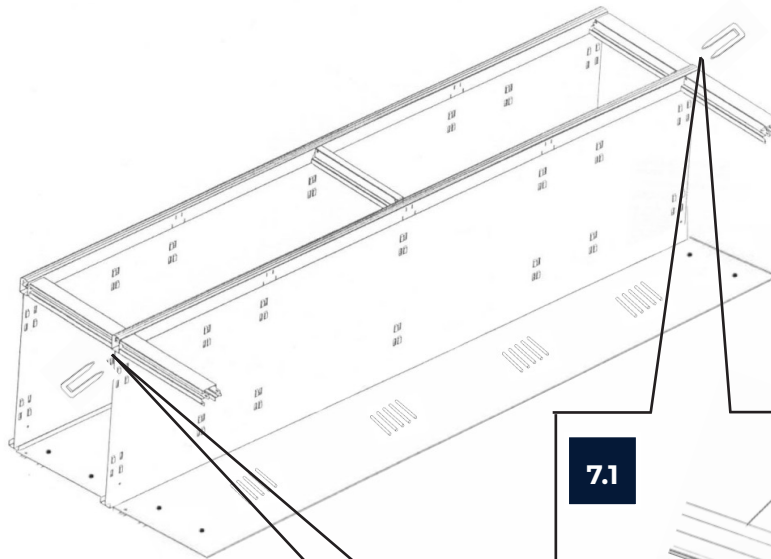

7



-  Additional Locker
-  Taquilla Adicional
-  Casier Supplémentaire
-  Erweiterungsspind

7.1

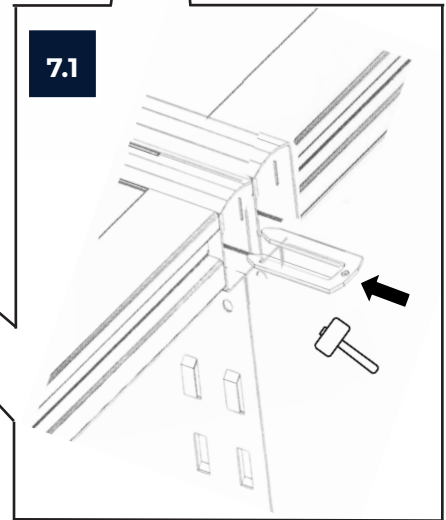

8

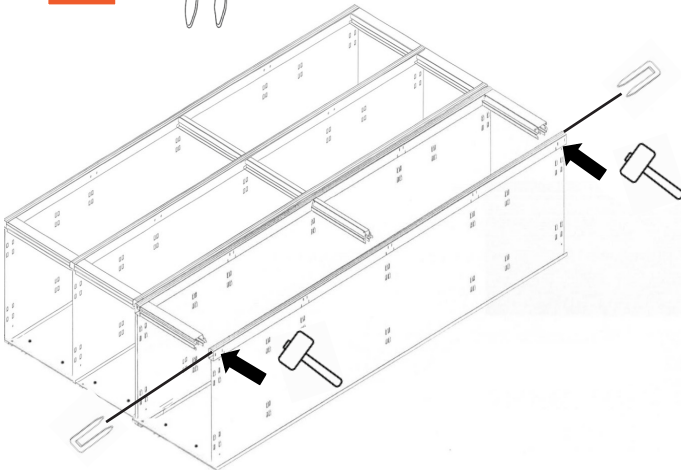

9

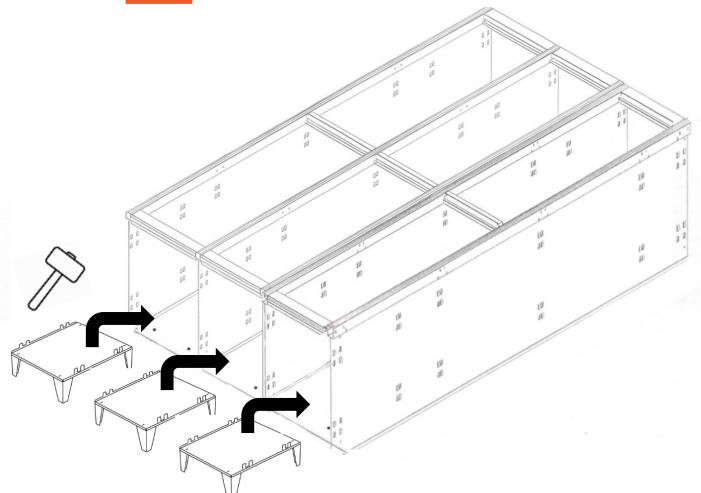

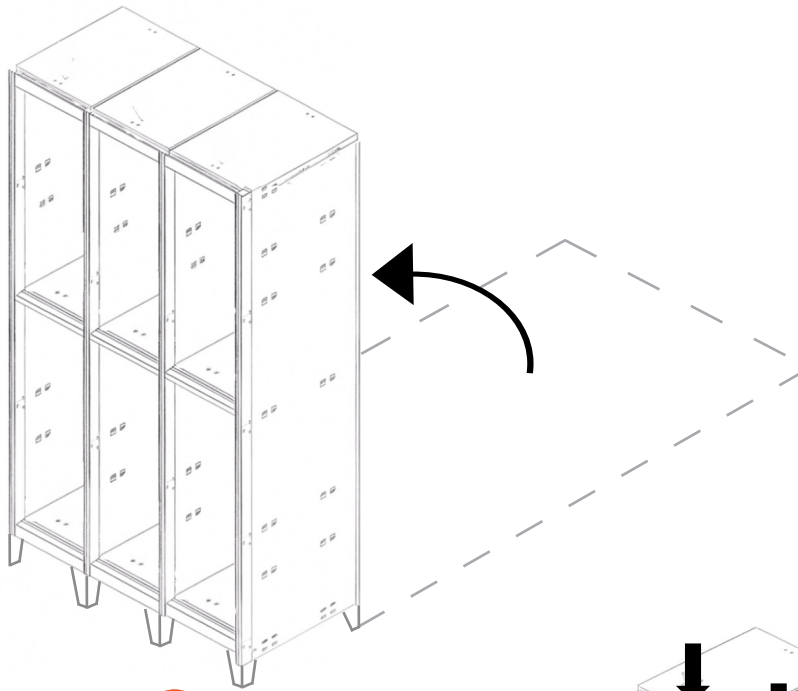

10





11



 The trays must be inserted rotated and taken to the end of the locker.

 Las bandejas deben introducirse giradas y llevarse hasta el final de la taquilla.

 Les étagères doivent être introduites en biais et poussées jusqu'au fond du casier.

 Die Fächer müssen gedreht eingeschoben und bis zum Ende des Spinds geschoben werden.

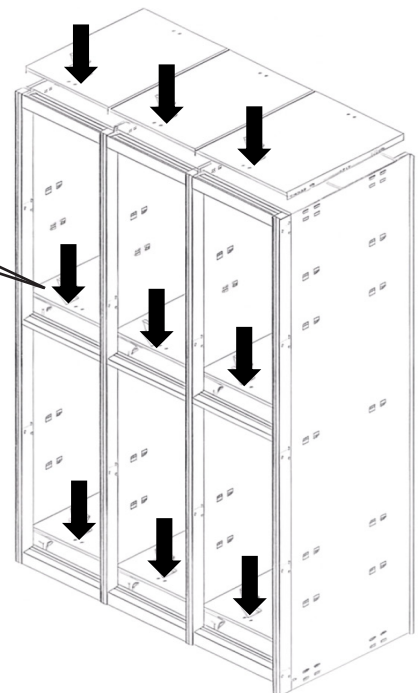
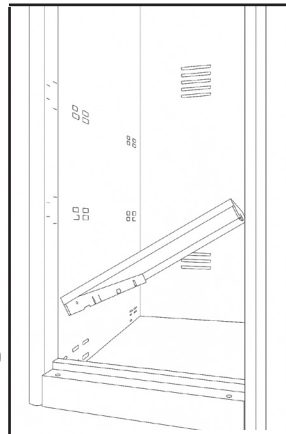

12

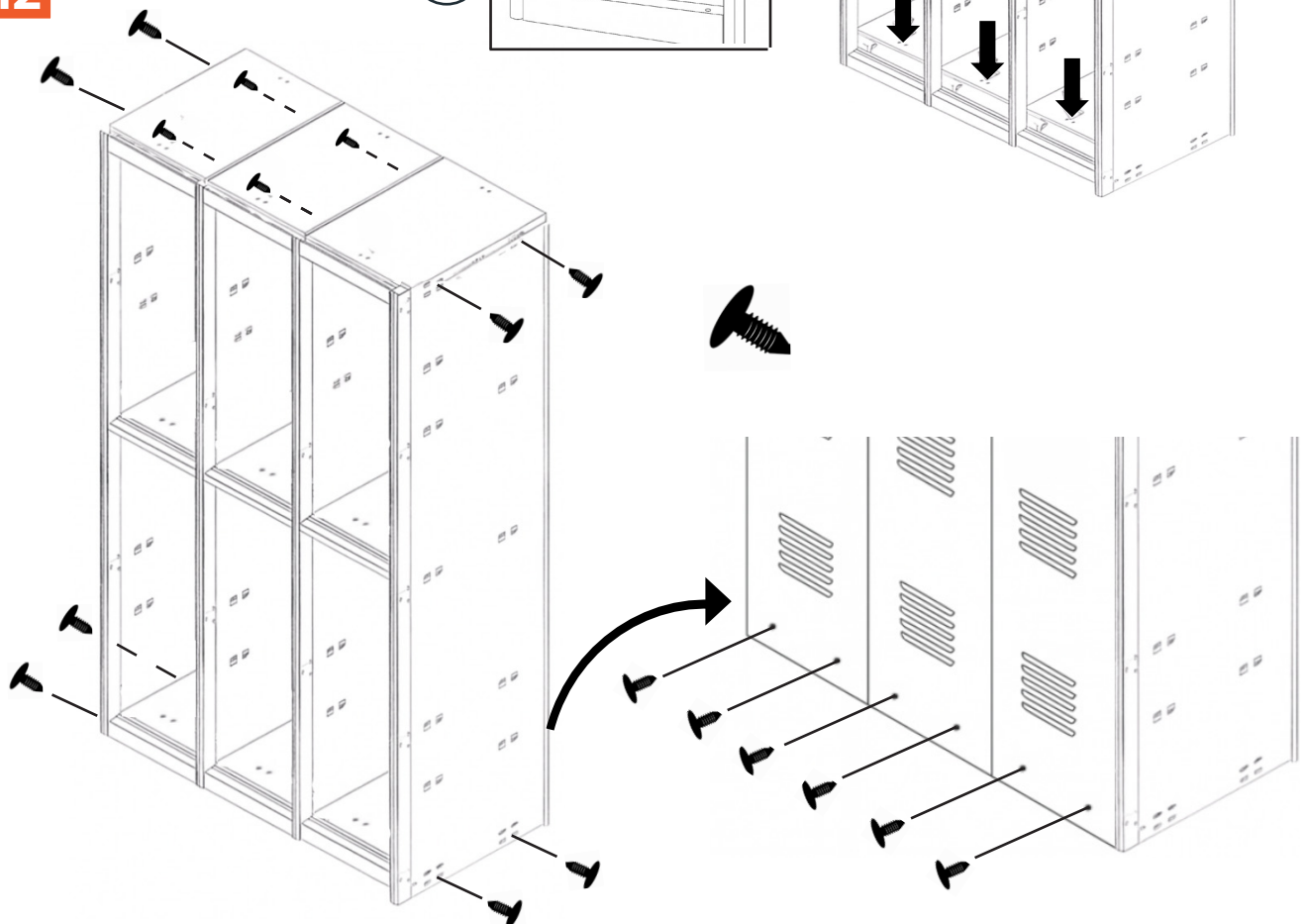

13

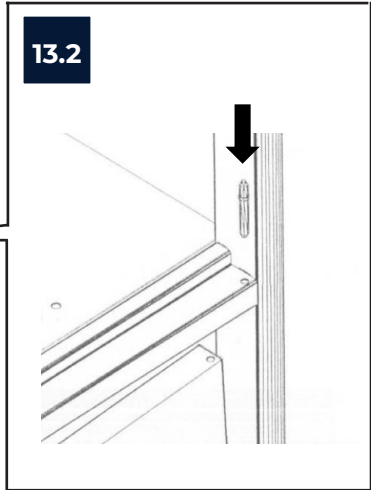
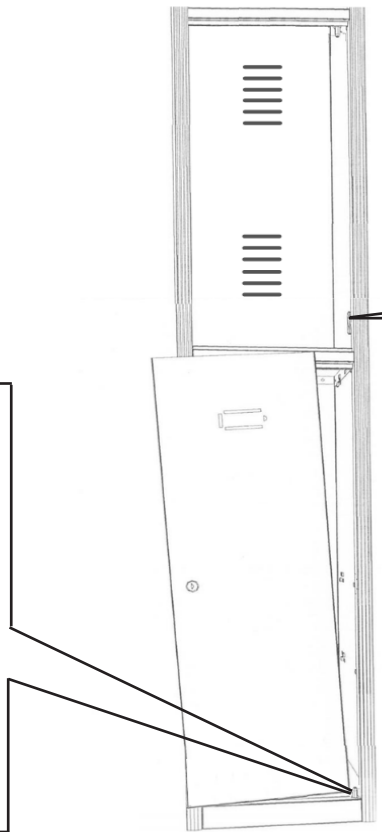
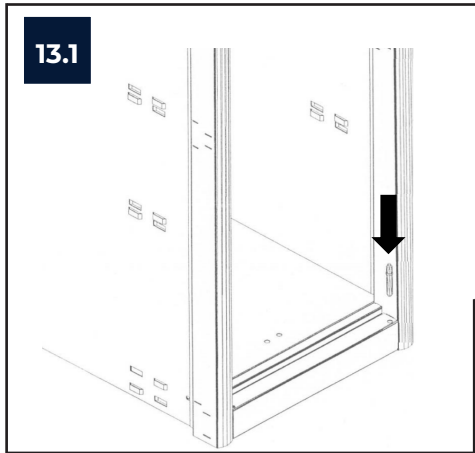
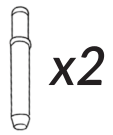

14

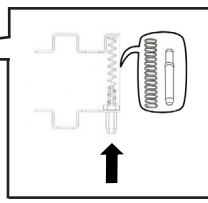
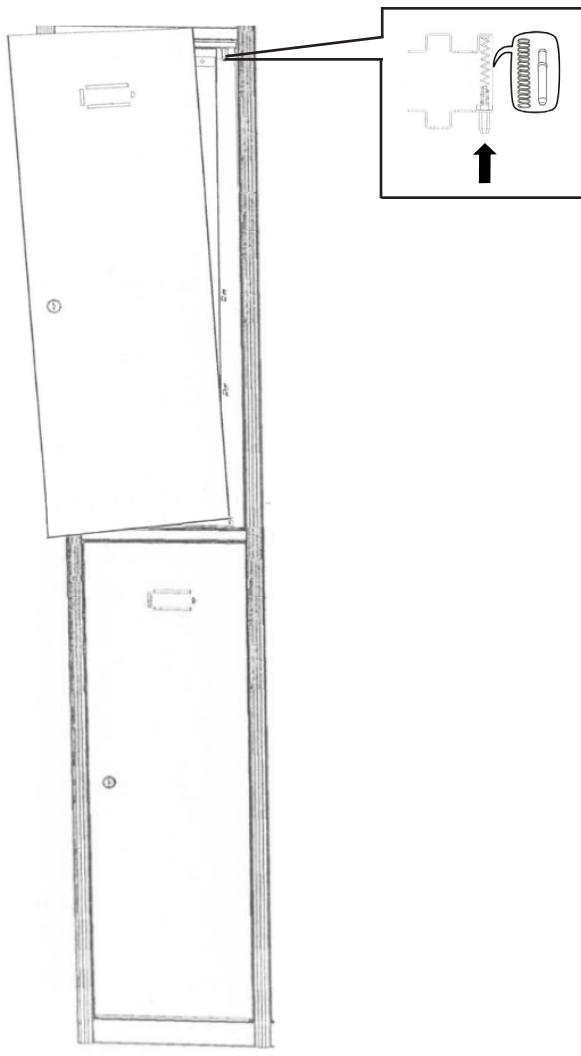

15

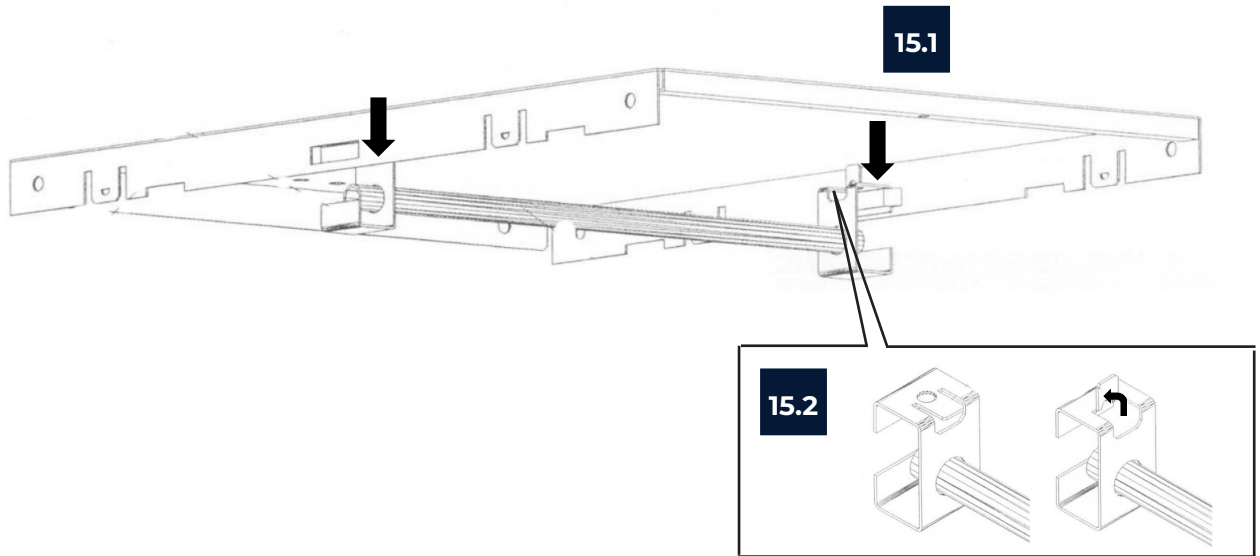

16

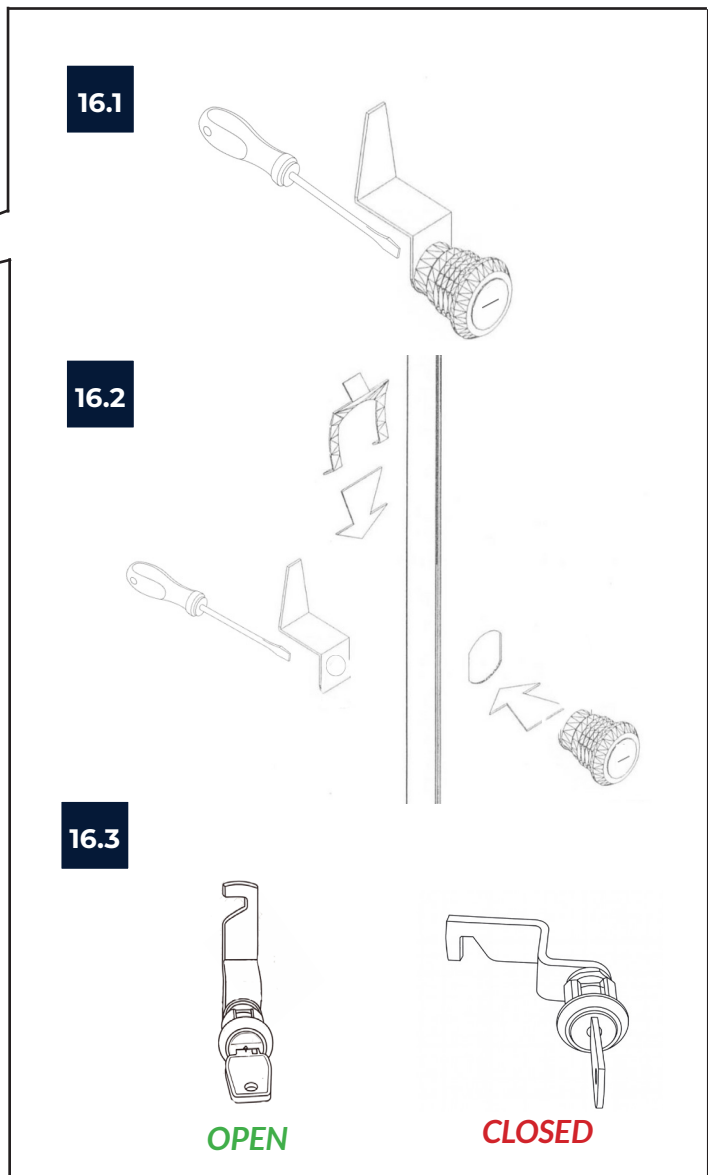
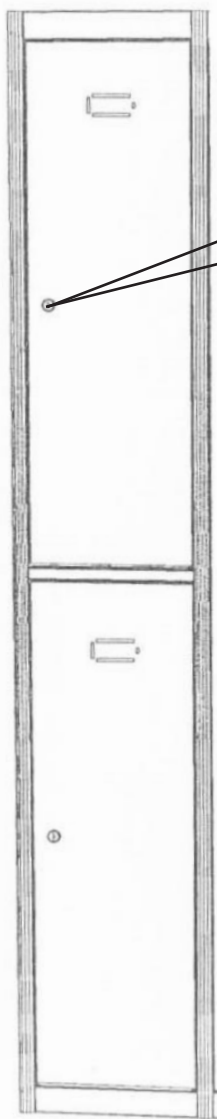

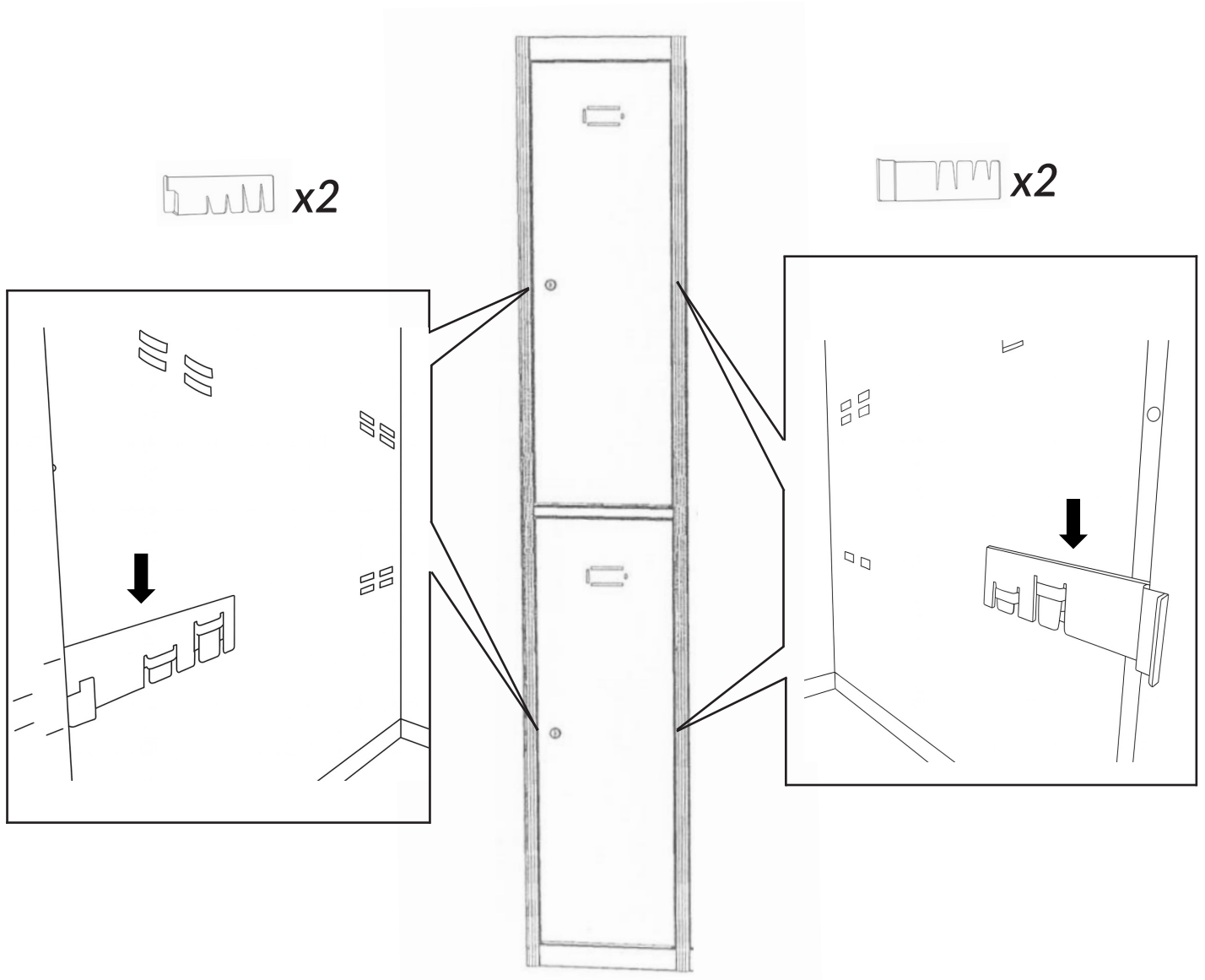

18

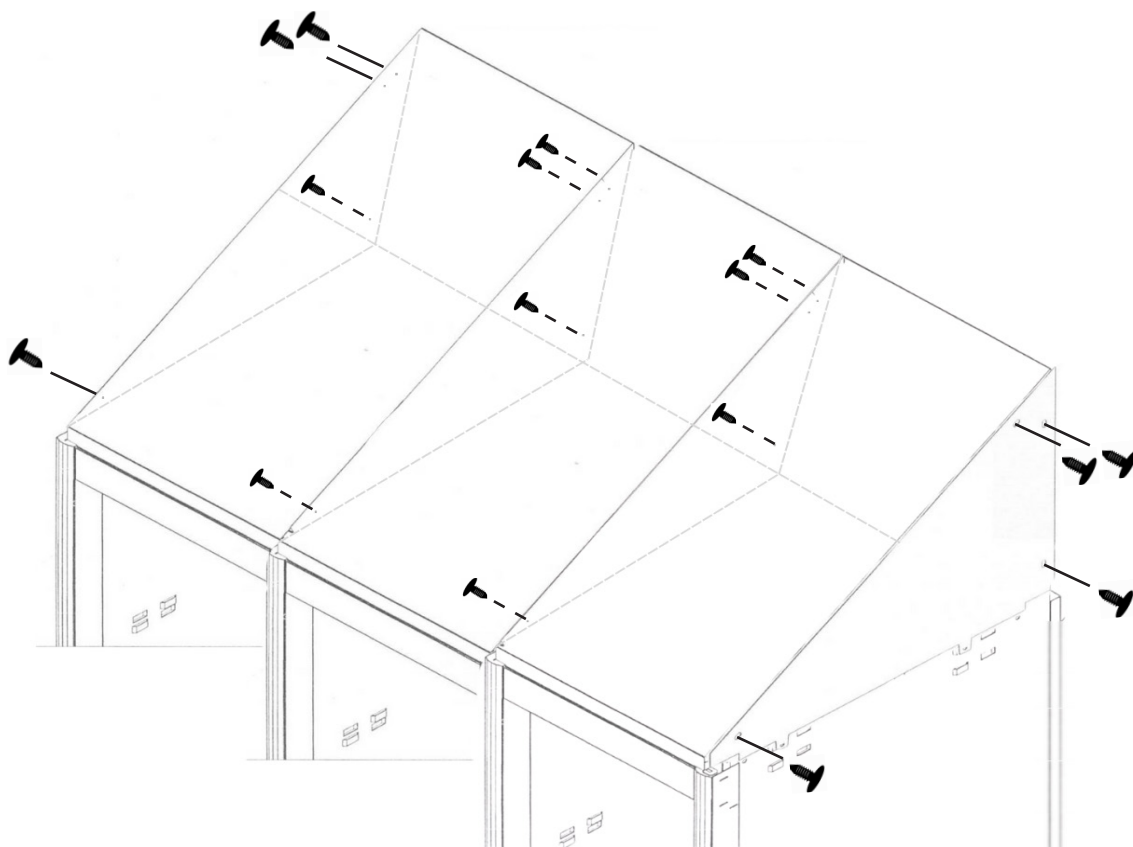
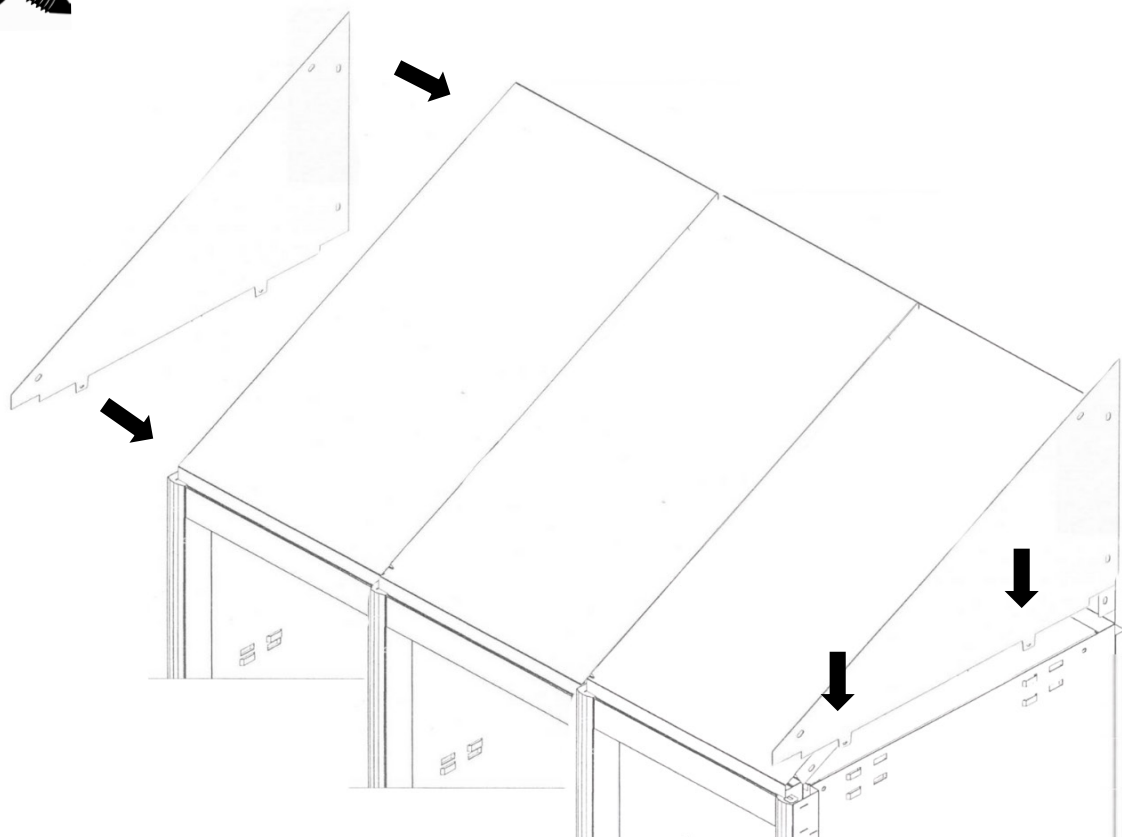



È necessario l'uso di un cacciavite
Schroevendraaier nodig
Konieczne użycie śrubokręta
Necessário uso de chave de fendas



Si consiglia di utilizzare un martello di gomma e guanti
We raden aan een rubberen hamer en handschoenen te gebruiken
Zaleca się użycie gumowego młotka i rękawic
Recomenda-se a utilização de um martelo de borracha e luvas

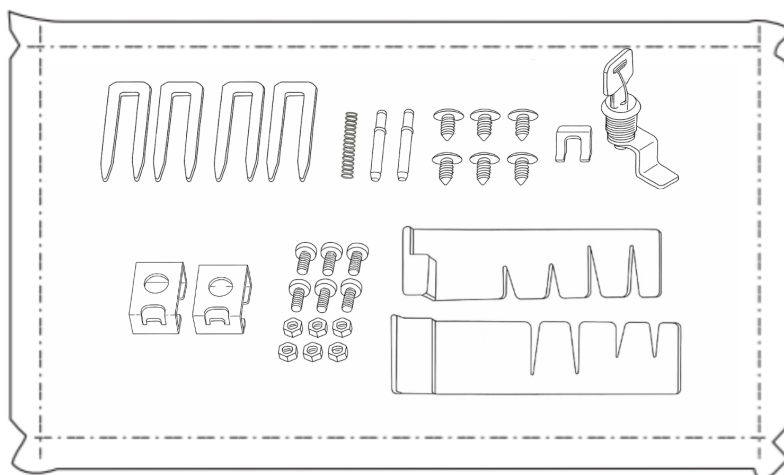

1

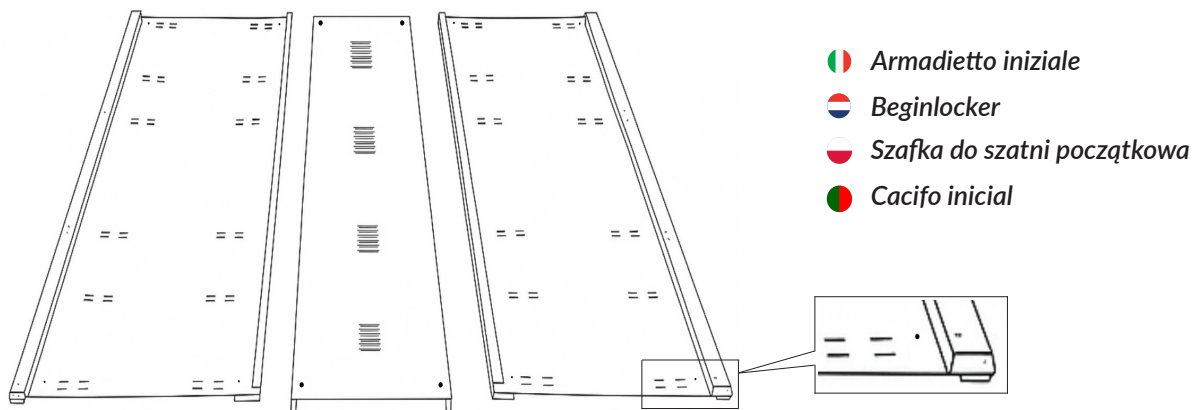

2

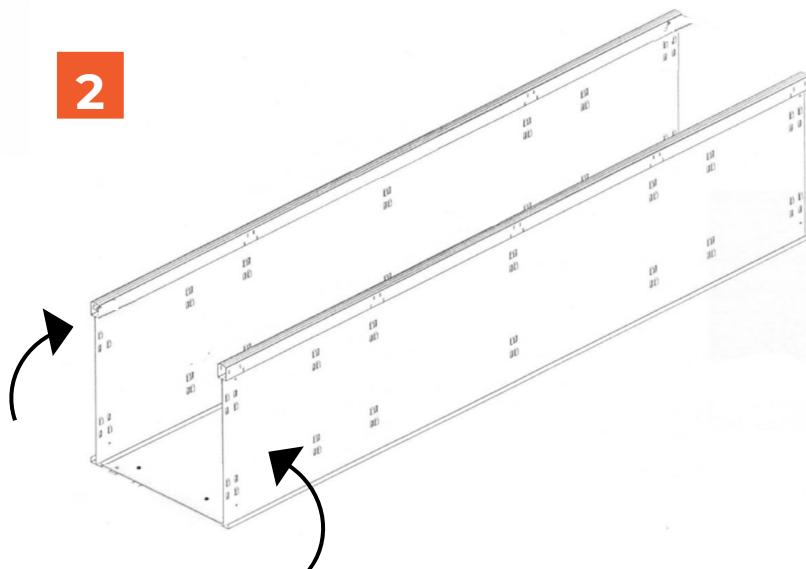

3

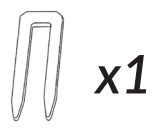

x1

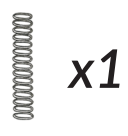

x1

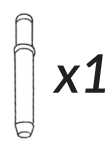

x1

3.1

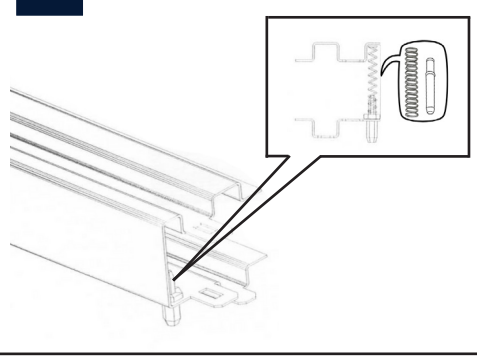

3.2

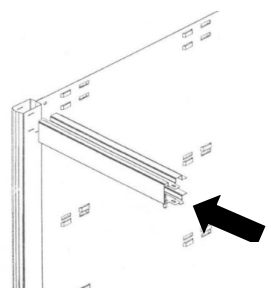

3.3

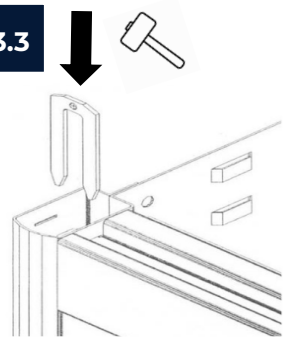

4

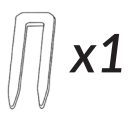

x1

4.1

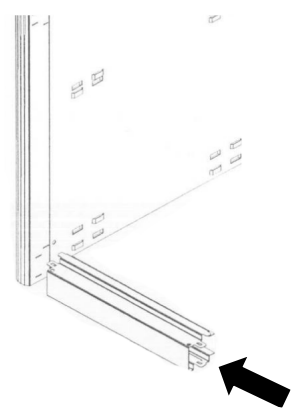

4.2

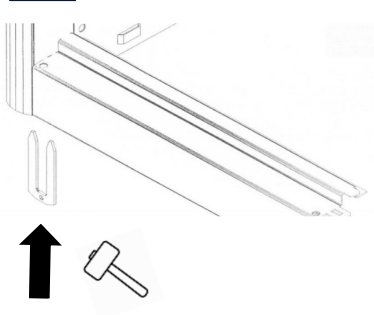

5

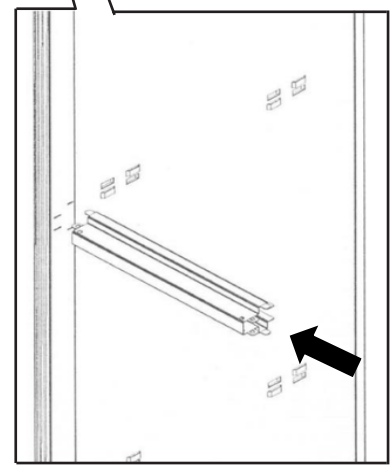



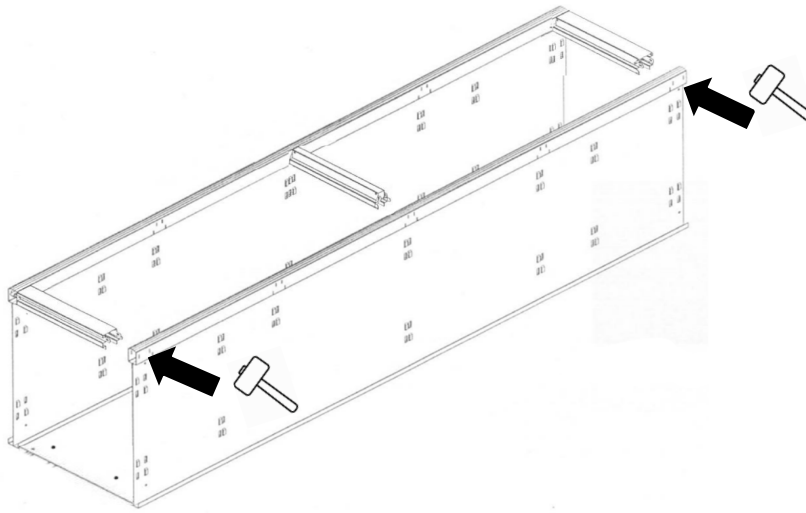

6

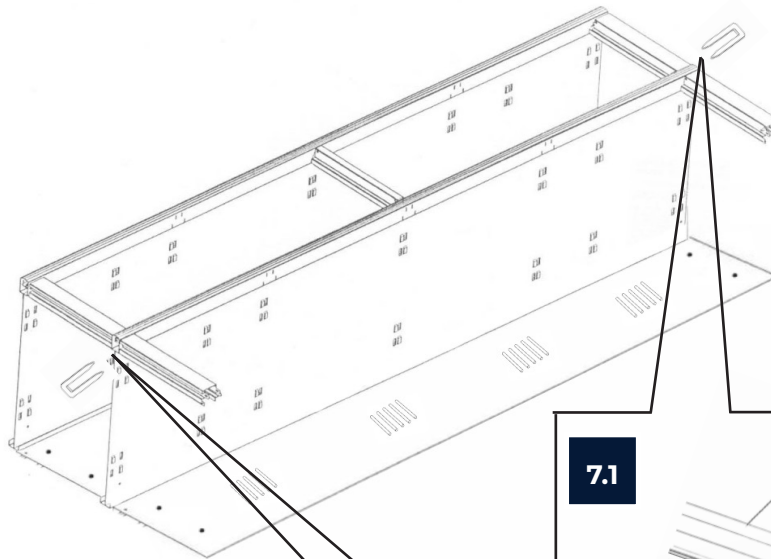

7



7.1

-  Armadietto Aggiuntivo
-  Aanbouwlocker
-  Szafka do Szatni Dodatkowa
-  Cacifo Adicional



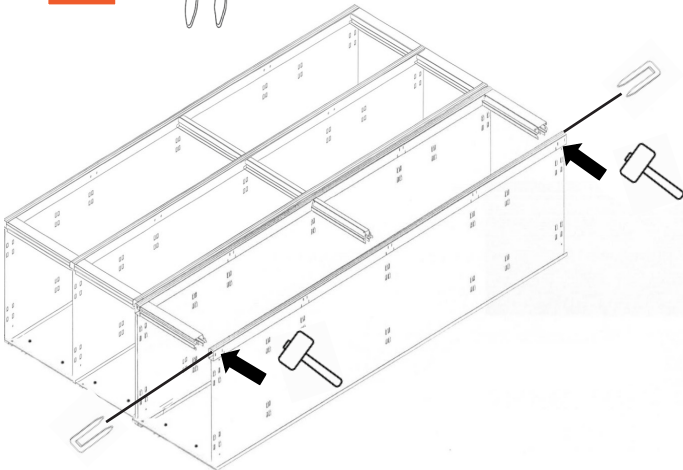

8

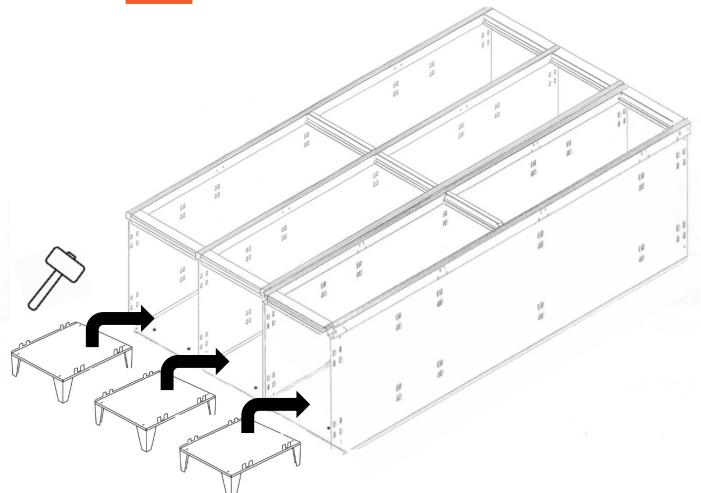

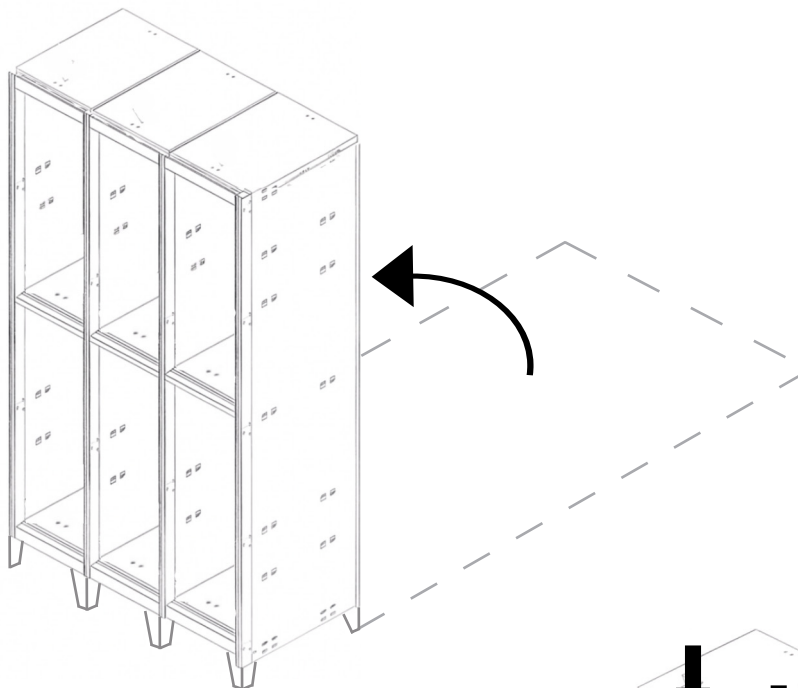
9



10**11**

-  I ripiani devono essere inseriti capovolti e portati fino al fondo dell'armadietto
-  Draai de legborden in de kast en tot aan het einde van de kast en duw ze omlaag.
-  Półki należy wsunąć obracając je lekko i wsuwając do końca szafki.
-  As bandejas devem introduzir-se de lado e devem levar-se até ao fundo do cacifo.

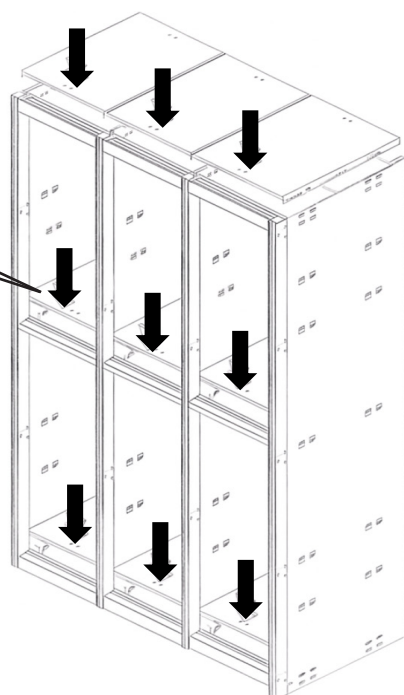
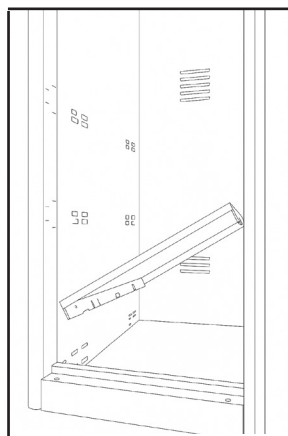
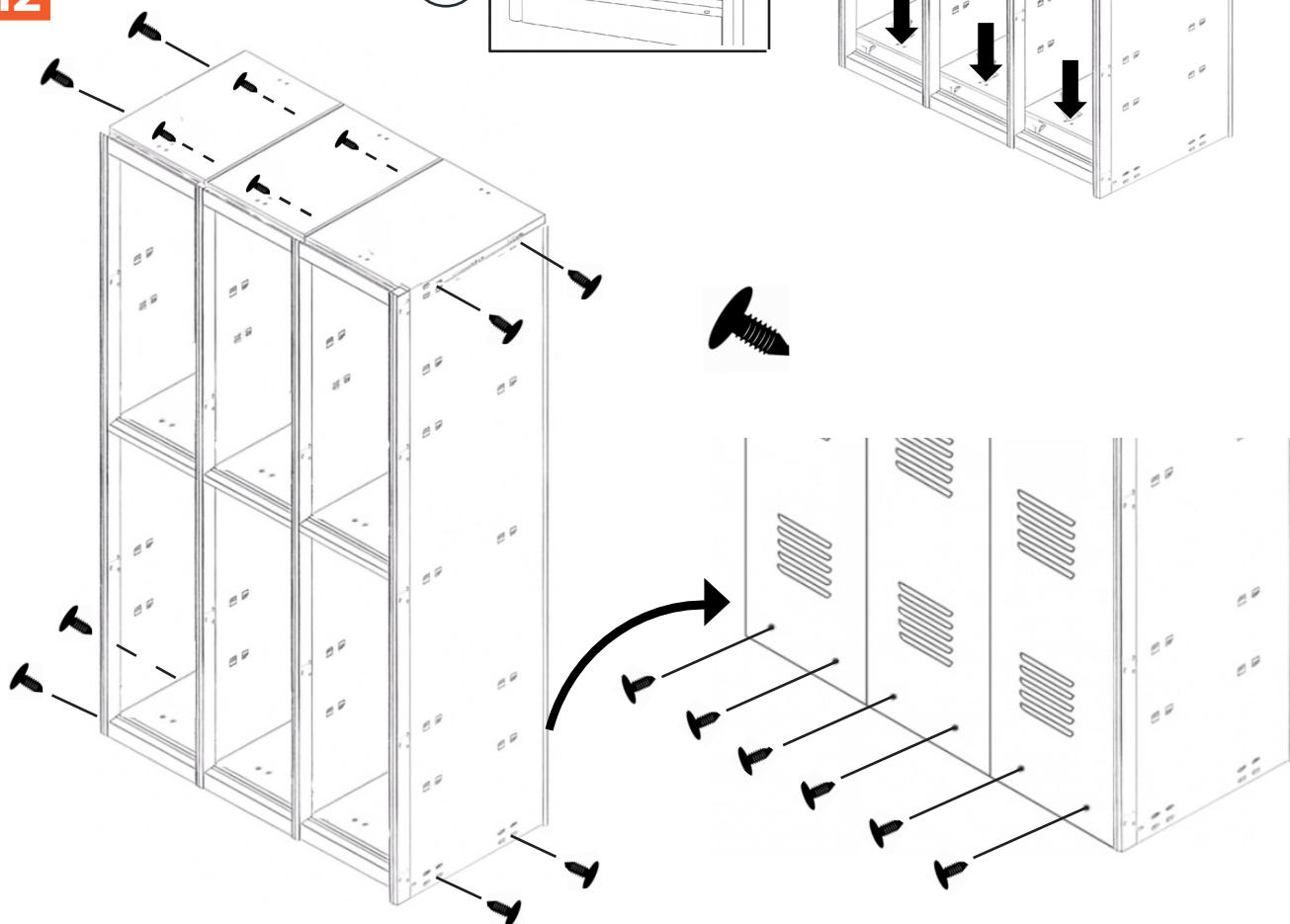
**12**

13

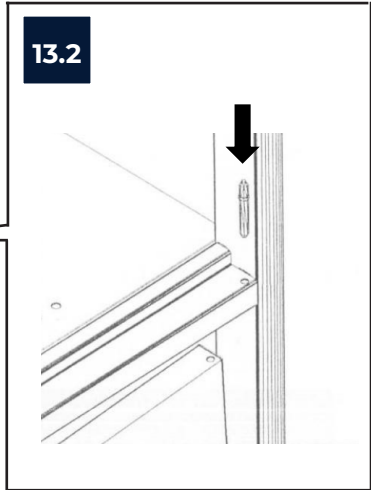
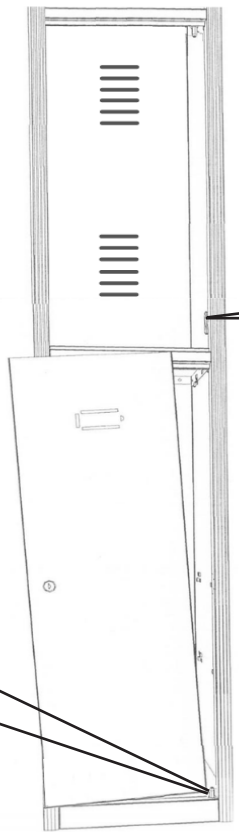
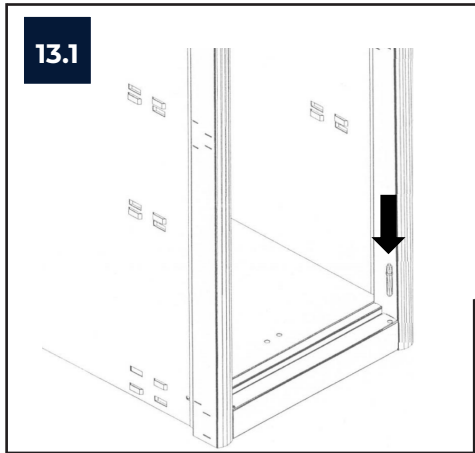
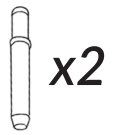

14

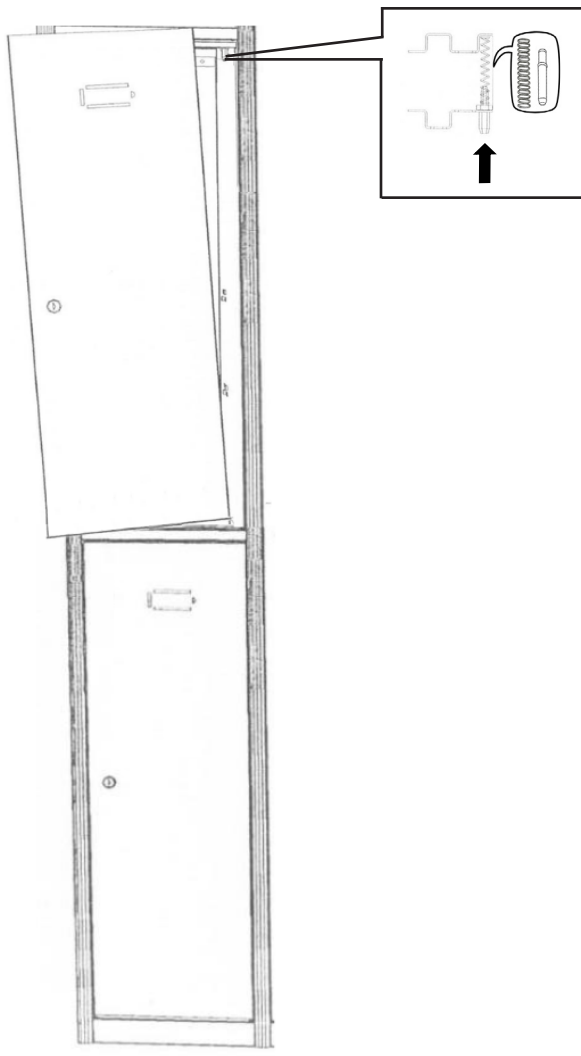

15

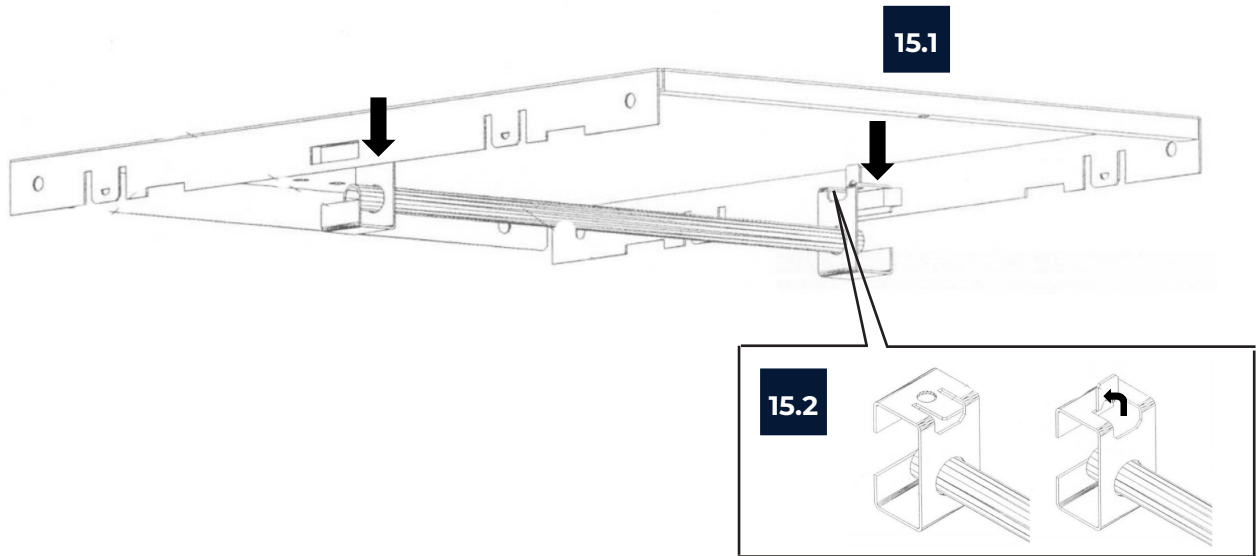

16

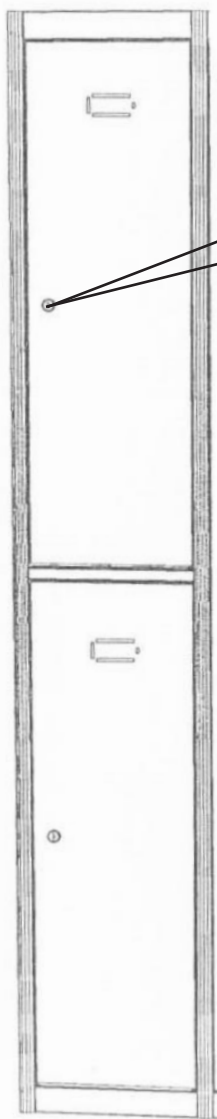

16.1

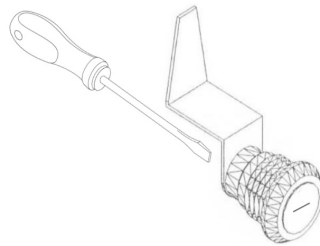

16.2

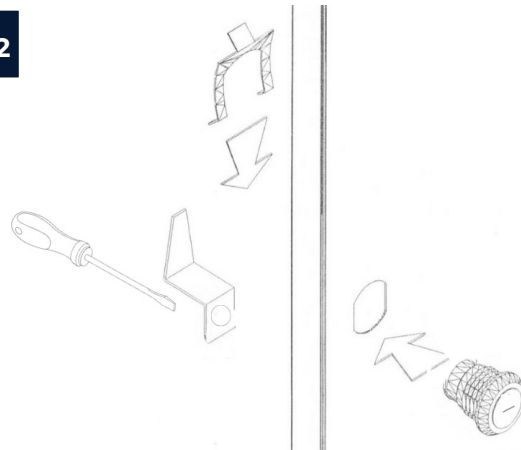

16.3

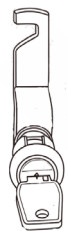

OPEN

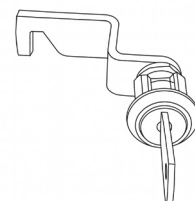

CLOSED

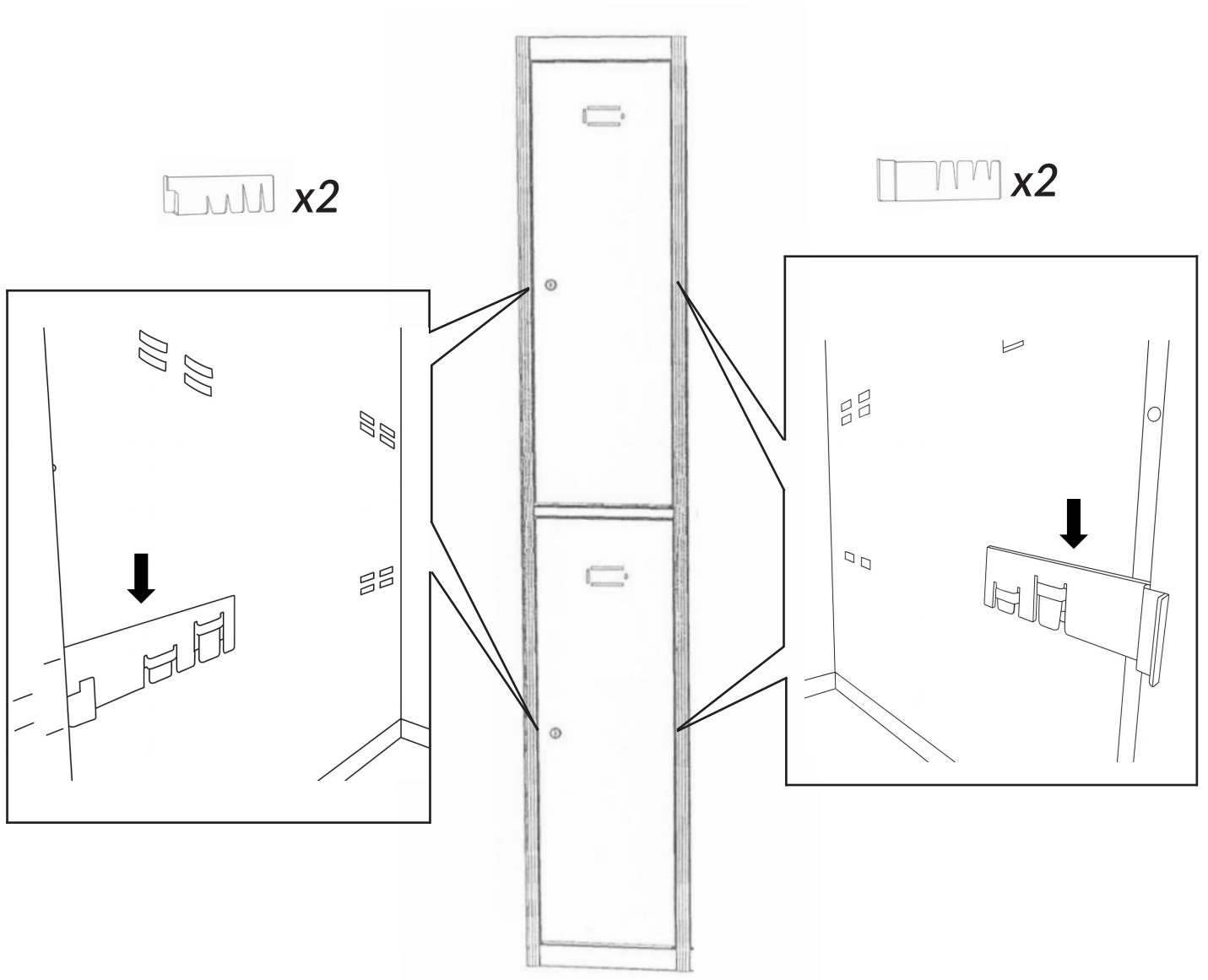

18

